

DYNABOX XL HOLLOW SHAFT

SMOOTH SHAFT FOR SHRINK DISC

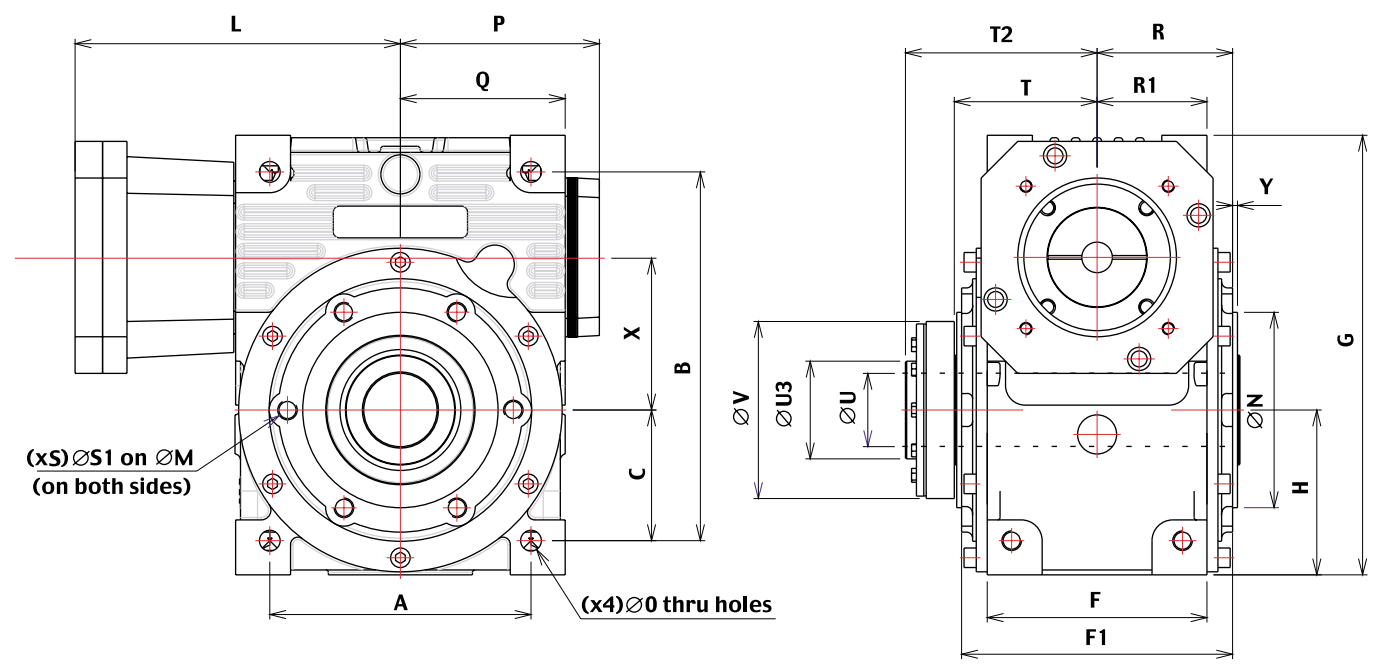

INPUT SHAFT VERSION

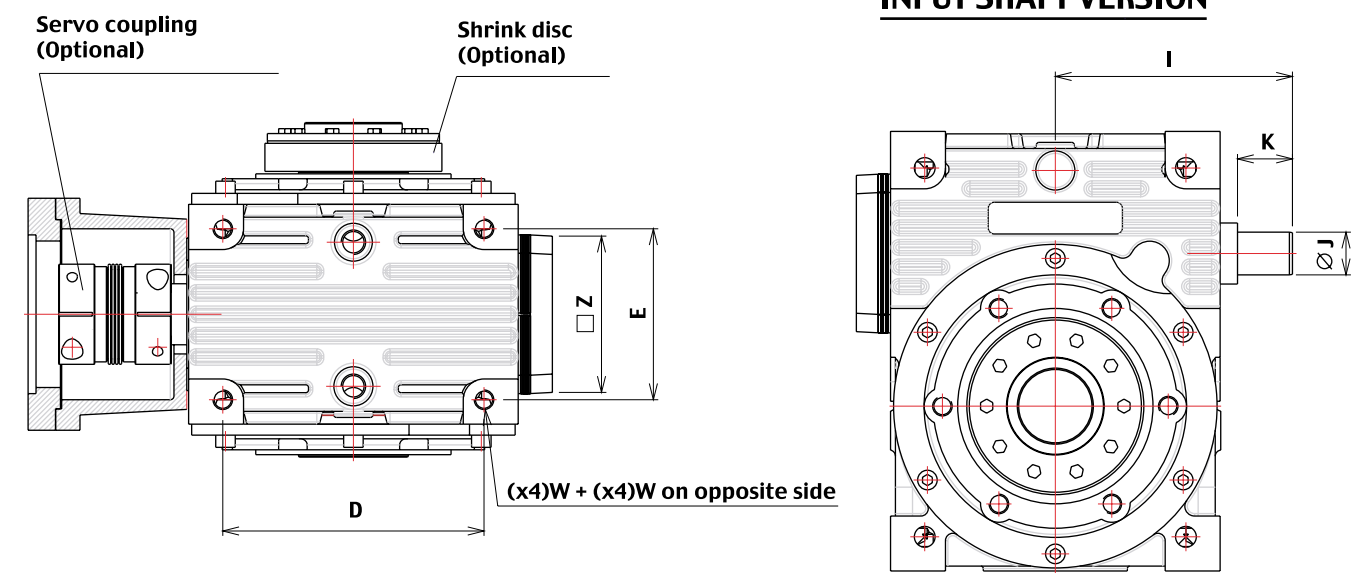

DYNABOX XL	125	160	200
A	214	284	342,5
B	302	377	483
C	107	142	171
D	214	284	342,5
E	140	150	224
F	180	198	288
F1	222	246	374
G	360	450	576
H	135	175	216
I	195	240	289
J	35	42	48
K	45	50	55
L	DEPENDS ON MOTOR		
M	185	230	300
N	160	190	250
O	17	22	28
P	163	204	251
Q	135	175	216
R	111	123	187
R1	90	99	144
S	6	6	8
S1	M16	M20	M20
T	117	129	194
T2	157	177	264
U	65	75	100
U3	80	90	140
V	145	155	230
W	M16	M20	M20
X	125	160	200
Y	4	5	5
Z	130	140	180

MOUNTING POSITIONS

	1	2	3	4
H				
V				
F				

Note : Positions F are shown with shrink disc on back side.